



Installation Guide
VE/VF Commodores
NA OTR



For 60 years Harrop Engineering has been at the forefront of designing, developing and manufacturing precision performance components. Today our innovative and logical approach is applied to low volume automotive OEMs and the performance aftermarket through a dedicated team of 65 staff. Core performance products include Superchargers, Engine Components, Brakes, Differentials and we are also the exclusive Australian Distributor for Forgeline Motorsport Wheels & Lingenfelter Performance Parts.

Harrop are also the preferred supplier of Eaton Supercharger and Traction Control technology including dual branded product designed and manufactured in-house. There are currently over 4000 components in our portfolio and this is growing daily as we continually develop more Harrop Performance Products.

Our high profile car manufacturing customers include Holden, HSV, FPV, Roush and Lotus.

We also supply to race teams from categories including F1, NASCAR and V8 Supercars and an extensive range of drag, circuit and off-road competitors. Just as importantly, a large portion of our customers are performance enthusiasts and weekend warriors who are highly passionate about their ride.

Please take a moment to review the following pages and learn why Harrop is the first choice in performance products.

Thank you for choosing Harrop and enjoy your Harrop Enhanced ride.

- Team HARROP



Introduction	1
Car Preparation	3
VE PRE MY12 Radiator Positioning	3
VF & VE MY12 Radiator Positioning	6
Assembly and Installation of the NA OTR with MAF	8
Assembly and Installation of the MAFless OTR	12



This document is meant only as a guide, as any vehicle modification should be completed by a certified technician who has the relevant experience and equipment to be competent of a safe and effective OTR installation.

Install Considerations

Before attempting installation, please review the notes below.

- VE GXP & HSV E2/3 with factory bonnet flutes can foul on OTR which may not allow the bonnet to close. Modification to bonnet may be required. Please contact the Harrop sales team before proceeding with installation for clarifications on fitment.
- VE commodores that have had the front radiator support changed may require VF mounting brackets for OTR & fascia panels, these parts can be supplied at additional cost.
- Aftermarket modifications could affect the installation of OTR - i.e aftermarket radiator.

1. Car Preparation

- 1.a. Removal of fascia panel where fitted.
- 1.b. Remove the intake duct.
- 1.c. Remove the standard MAF sensor.
- 1.d. Remove the standard air box.
- 1.e. Cut away 490mm of rubber seal from the inside of the bonnet as shown.

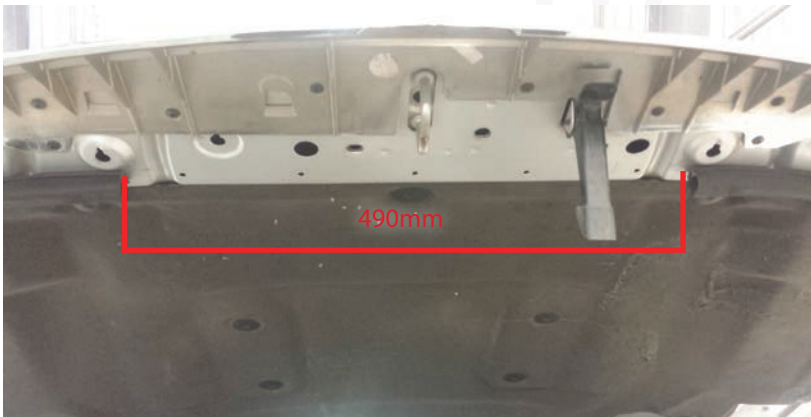

2. VE PRE MY12 Radiator Positioning

2.a. Remove the top two radiator mounts. To remove the upper radiator mounts, lift the locking clip up until it stops against its internal catch. Using a flat head screw driver depress the internal stop tab found on the LH side of the locking clip/plate and lift it out completely.

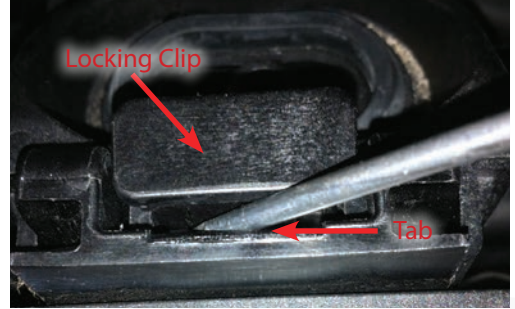

2.b. Using a flat screw driver, place it in the slot inside the top mount and lever the ratchet tab away far enough to unlock it and wiggle the mount upwards and remove.

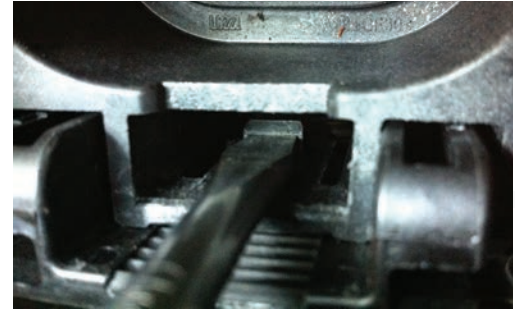
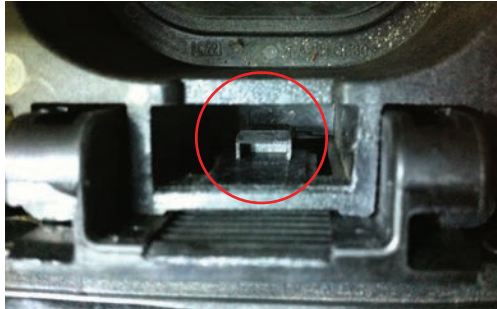

2.c. Remove the two lower sections of the mounts. Remove the 2 M6 bolts. Note: Retain the bolts to use with the OTR specific radiator brackets.

2.d. Use needle nose pliers or similar to compress the clips on the loom and push them through the lower section of the radiator mount. There are 2 clips for each mount.



3.a. Remove the fastener that holds the condenser on to the radiator on the RH side of the car.



3.b. Push the radiator back towards the engine and install the RH VE OTR radiator bracket.

3.c. The OTR radiator bracket locates on the same mounting face as the standard radiator mount and holds the radiator at the condenser mount.

3.d. Use the existing screws from the standard radiator mount and the condenser to secure the new radiator bracket in place.

3.e. One of the 2 plastic clips on the loom can now be pushed into the remaining hole on the radiator bracket to hold the loom in place.



4.a. Remove the existing screws securing the condenser on to the radiator on the LH side of the car and repeat the process to install the LH VE OTR radiator bracket.

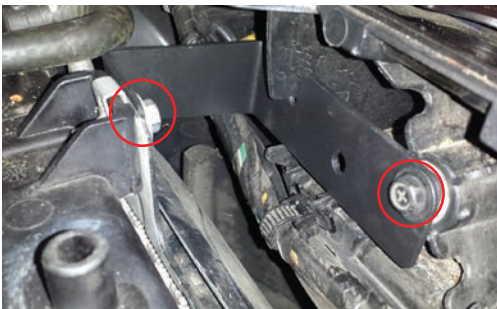

5. VF & VE MY12 Radiator Positioning

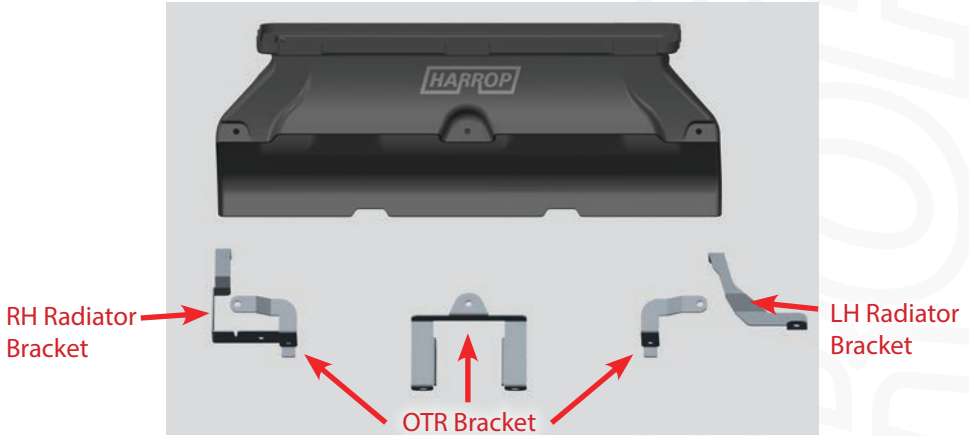

5.a. Remove the radiator mounts holding the top of the radiator in two places.

5.b. Remove the 2 M6 bolts holding the upper radiator mounts.

5.c. Push the radiator back to release the upper radiator mounts, remove upper radiator mounts.



5.d. Remove the two lower sections of the mounts. Remove the 2 M6 bolts.

Note: Retain the bolts to use with the OTR specific radiator bracket



- 6.a. Remove the torx screw from the washer filler bracket.
- 7.a. Remove the fan screw from the rear LH of the radiator.
- 8.a. Position the LH radiator bracket as shown. Fit the screw back through the radiator bracket to secure the radiator bracket and fan.
- 8.b. The front of the bracket will slide in between the washer filler bracket and the radiator support panel. Insert the torx screw and tighten.

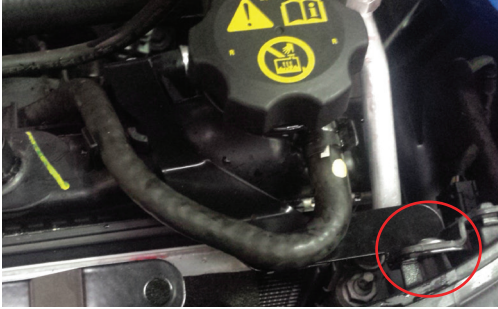

- 9.a For VF place the RH OTR bracket onto the mounting face for the standard radiator mount, place the RH radiator bracket over the OTR bracket as shown below. Push the radiator bracket down on top of the radiator to hold it in place. Fasten using the standard M6 bolt.
- Note: VE MY12 does not require the OTR brackets.

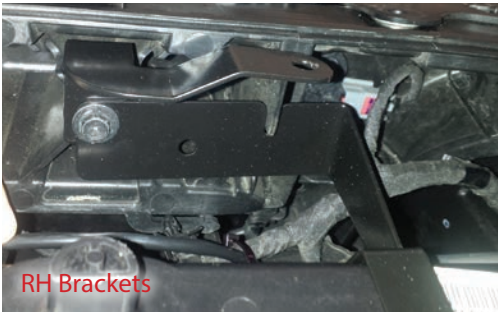

- 10.a. Fit the LH OTR bracket onto the mounting face for the standard radiator mounts.
- 10.b. Place the centre OTR bracket onto the back of the bonnet latch M8 bolts.
- 10.c. Fasten using the two nylock M8 nuts supplied in the bracket kit. (M8 bolts and washers supplied if required.)

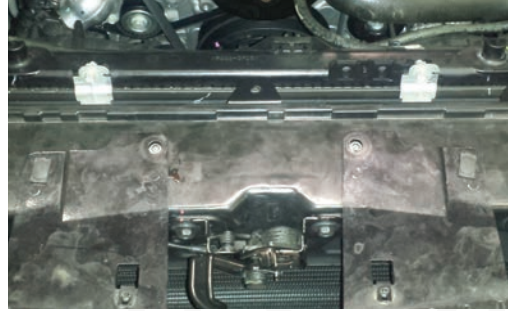
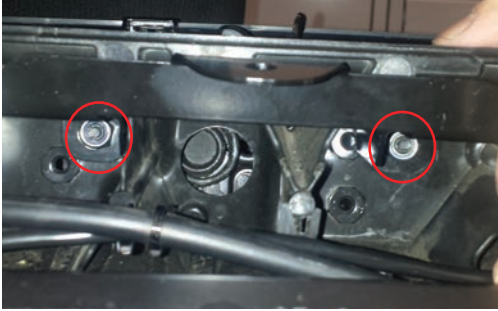

11. Assembly and Installation of the NA OTR with MAF

11.a. Place the factory MAF into the large oval shaped boot as shown.
Note: The flat section of rubber boot must be at the bottom.
Secure with a 91-114mm hose clamp.



11.b. Place the second rubber boot on the other end of the MAF tube at an angle of 45 degrees.
Secure with a 91-114mm hose clamp.

11.c. Insert the quick connect fitting into the second rubber boot as shown.
Ensure the locating bead locks the fitting into position.

11.d. Fasten the fitting in place with the supplied 16mm green band cobra clamp.

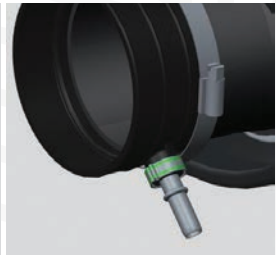
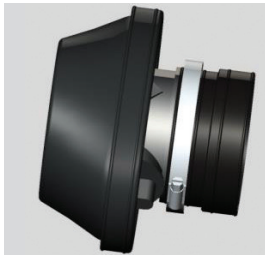

VE/VF NA OTR

INSTALLATION GUIDE



11.e. Push the MAF tube assembly into the rear section of the OTR.
Secure with the 105-176mm hose clamp.

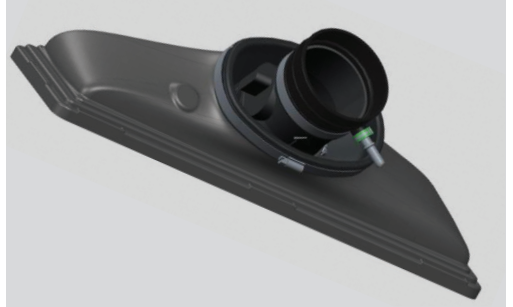
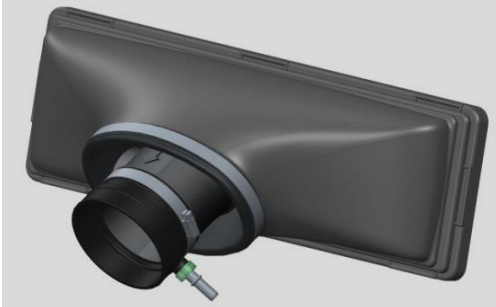

11.f. Insert the duckbill drain and 2 grommets into the bottom front half of the OTR.
- VE Pre MY12 uses grommets with internal diameter 13mm.
- VF & VE MY12 uses grommets with internal diameter 20mm.

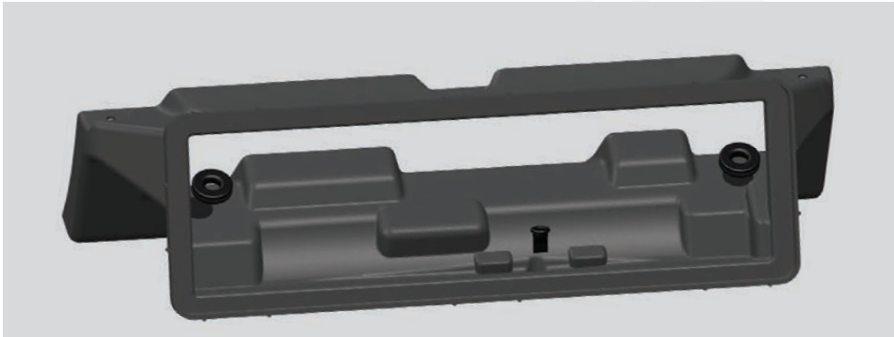

11.g. Place the filter into the rear of the OTR.
Note: The side of the filter with 3 steps should be placed into the back of the OTR.



11.h. Place the front of the OTR over the rear of the OTR. Secure the two halves of the OTR together with the 8 spring clips, ensure they are centred in the clip pockets. (3 clips on the top, 3 on the bottom and 1 either side.)

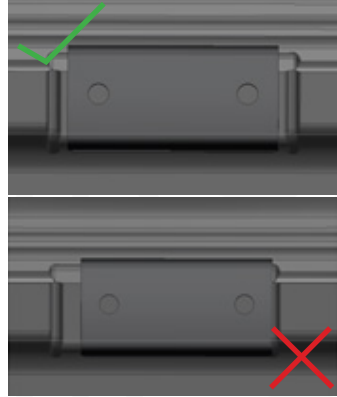

12. Fit the OTR

12.a. Slide the OTR into the space between the radiator and the front bar.

Note: Hold the looms back as you insert the OTR to avoid catching the OTR on the looms.

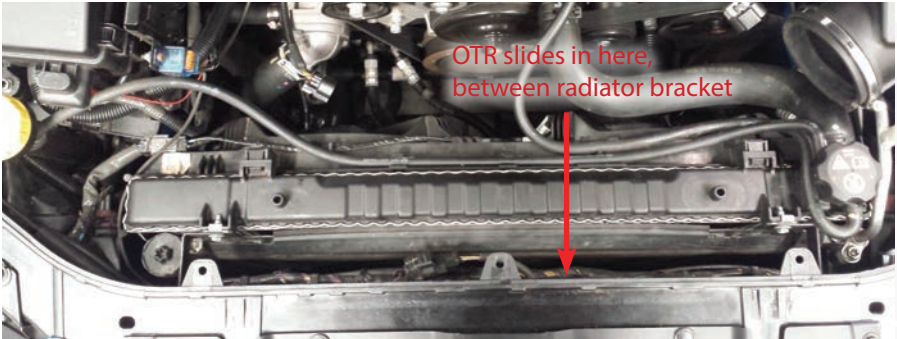

12.b. Align the grommet holes with the bosses on the radiator and gently push the OTR down until it is firmly seated on top of the radiator.

12.c. Connect the wiring harness to the MAF sensor. For VE an extension loom is required and supplied.

12.d. Fit the rubber boot on the back of the OTR to the throttle body and secure with a 91-114mm hose clamp.

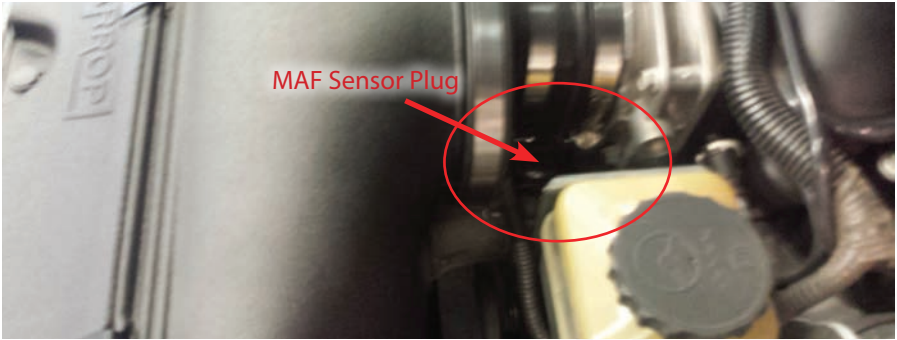

13.a. Cut 230mm from the supplied hose and push in the straight quick connect fitting and the 90 degree quick connect fitting. Overall length 285mm
(Use oil and or a heat gun to aid inserting the fittings into the hose.)

13.b. Connect the Straight quick connect on the supplied breather hose to the right hand rocker cover inlet. Connect the 90 degree quick connect to the fitting in the rear boot of the OTR.



14.a. Push the 3 scrivers through the top half of the OTR into the previously fitted brackets or standard mounts to hold the OTR in position.

15.a. Check OTR is secure, all hose clamps are tight, hoses are free from moving parts and all looms are connected.

16.a. VE-VF NA OTR with MAF install complete awaiting tune.

17. Assembly and Installation of the MAFless OTR

17.a. Drill a 13.0-13.5mm hole in the rear section of the OTR, central to the boss as shown.

17.b. Fit the rubber washer over the quick connect fitting, as per second image below.



17.c. Push the fitting through the rear section of the OTR.

17.d. Use the 12.7mm push on clip to secure the breather fitting in place.

(A socket can be used to assist pushing the locking clip on.)

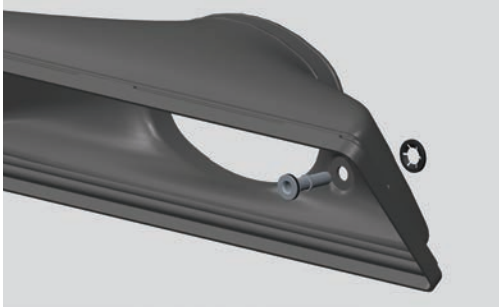

18.a. Fit the MAFless rubber boot to the rear section of the OTR as shown.

18.b. Secure with the 105-176mm hose clamp.

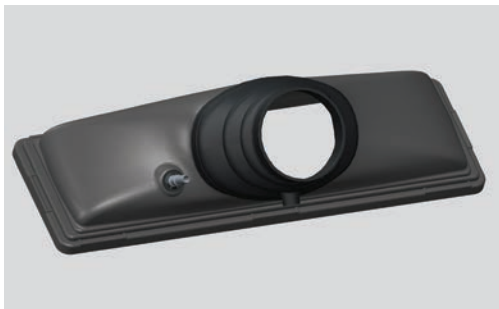

VE/VF NA OTR

INSTALLATION GUIDE



19.a. Insert the IAT sensor into the bottom of the boot.

20.a. Insert the duckbill drain and 2 grommets into the bottom front half of the OTR.

- VE Pre MY12 uses grommets with internal diameter 13mm.

- VF & VE MY12 uses grommets with internal diameter 20mm.

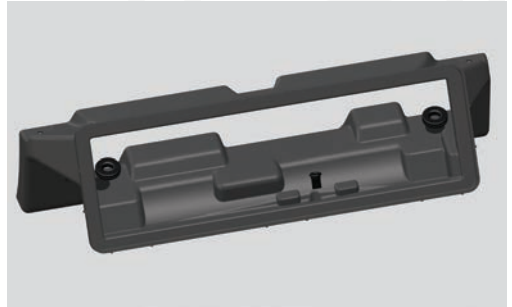

21.a. Place the filter into the rear of the OTR.

Note: The side of the filter with 3 steps should be placed into the back of the OTR.



22.a. Place the front of the OTR over the rear of the OTR.

22.b. Secure the two halves of the OTR together with the 8 spring clips, ensure they are centred in the clip pockets.

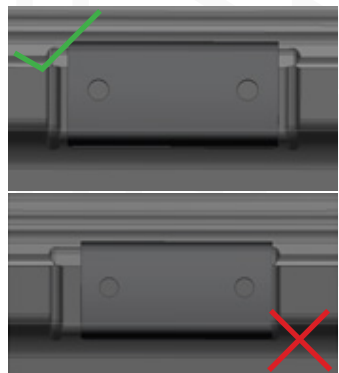

23. Fit the OTR

23.a. Slide the OTR into the space between the radiator and the front bar.

Note: Hold the looms back as you insert the OTR to avoid catching the OTR on the looms.

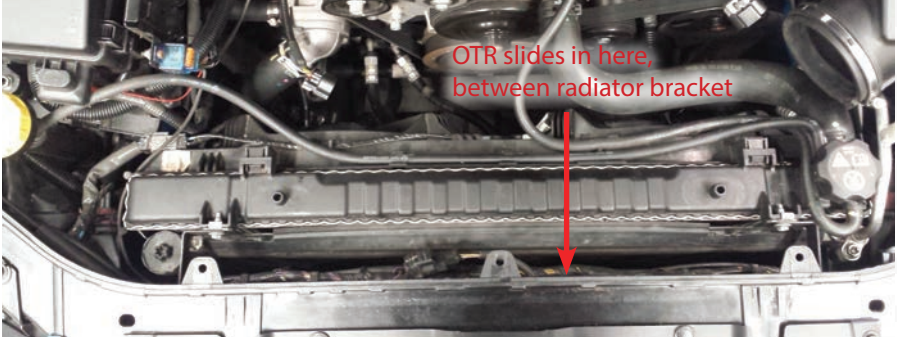

23.b. Align the grommet holes with the bosses on the radiator and gently push the OTR down until it is firmly seated on top of the radiator.

23.c. Plug the IAT loom into the IAT sensor in the bottom of the rubber boot, plug the other end of the loom into the MAF plug on the wiring harness.

23.d. Fit the rubber boot on the back of the OTR to the throttle body and secure with a 91-114mm hose clamp.

24.a. Insert the straight quick connect fitting and the 90 degree quick connect fitting into the hose provided. Overall length 450mm (Use oil or a heat gun to insert the fittings into the hose.)

24.b. Connect the straight quick connect on the supplied breather hose to the right hand rocker cover inlet. Run the breather hose under the rubber boot and connect the 90 degree quick connect to the fitting in the back section of the OTR.



25.a. Push the 3 scrivers through the top half of the OTR into the previously fitted brackets or standard mounts to hold the OTR in position.

26.a. Check OTR is secure, all hose clamps are tight, hoses are free from moving parts and all looms are connected.

27.a. VE-VF NA OTR with MAFless install complete awaiting tune.



Harrop Engineering

96 Bell Street
Preston, VIC
3072

e sales@harrop.com.au

t 03 9474 0900

w harrop.com.au

ENGINEERING PERFORMANCE SINCE 1955